



Macroblock

Advance Information

MBI5169

8-bit Constant Current LED Sink Driver with Error Detection

Features

- Error Detection mode to detect individual LED open-circuit errors
- 8 constant-current output channels
- Constant output current invariant to load voltage change
- Excellent output current accuracy:
between channels: <math>< \pm 4\% \text{ (max.)}</math>, and
between ICs: <math>< \pm 6\% \text{ (max.)}</math>
- Output current adjusted through an external resistor
- Constant output current range: 5 -120 mA
- Fast response of output current, \overline{OE} (min.): 400 ns
- 25MHz clock frequency
- Schmitt trigger input
- 5V supply voltage

MBI5169CN

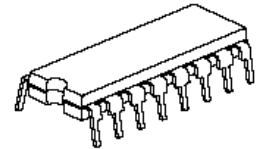

DIP16-P-300-2.54 Weight: 1.02g(typ)

MBI5169CD

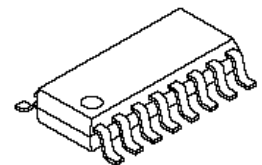

SOP16-P-150-1.27 Weight: 0.13g(typ)

MBI5169CP

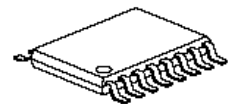

SSOP16-P-150-0.64 Weight: 0.07g(typ)

Current Accuracy		Conditions
Between Channels	Between ICs	
<math>< \pm 4\%</math>	<math>< \pm 6\%</math>	$I_{OUT} = 10 \text{ mA to } 60 \text{ mA}, V_{DS} = 0.6V$
<math>< \pm 6\%</math>	<math>< \pm 12\%</math>	$I_{OUT} = 60 \text{ mA to } 100 \text{ mA}, V_{DS} = 0.8V$

MBI5169 8-bit Constant Current LED Sink Driver with Error Detection

Product Description

MBI5169 succeeds MBI5168 and is designed for LED displays with open-circuit Error Detection extension. MBI5169 exploits PrecisionDrive™ technology to enhance its output characteristics. MBI5169 contains a serial buffer and data latches, which convert serial input data into parallel output format. At MBI5169 output stage, eight regulated current ports are designed to provide uniform and constant current sinks for driving LEDs within a wide range of Vf variations.

While MBI5169 is used in their system design for LED display applications, e.g. LED panels, it provides users with great flexibility and device performance. Users may adjust the output current from 5 mA to 120 mA through an external resistor, R_{ext} , which gives users flexibility in controlling the light intensity of LEDs. MBI5169 guarantees to endure maximum 17V at the output port. The high clock frequency, 25 MHz, also satisfies the system requirements of high volume data transmission.

MBI5169 exploits the idea of Share-I-O™ technology to extend its performance ; in addition, MBI5169 is backward compatible with MBI5168 in both electrical characteristics and package aspect. With Share-I-O™ technology, users can, without changing the printed circuit board originally for MBI5168, let MBI5169 enter a special function mode, an Error Detection mode, just by setting a sequence of signals on LE(ED1), \overline{OE} (ED2) and CLK input pins. In the Error Detection mode, MBI5169 detects the status of individual LED connected to MBI5169. The status will be saved in a built-in register. Then, a system controller may read, through SDO pin, the error status from the register to know whether LEDs are properly lit or not. By setting another sequence of signals on LE(ED1), \overline{OE} (ED2) and CLK input pins, MBI5169 may resume to a Normal mode and perform as MBI5168. In **Application Information**, users can get detailed ideas about how MBI5169 works in the Error Detection mode.

A Share-I-O™ technique is specifically applied to MBI5169. By means of the Share-I-O™ technique, an additionally effective function, Error Detection, can be added to LED drivers, however, without any extra pins. Thus, MBI5169 could be a drop-in replacement of MBI5168. The printed circuit board originally designed for MBI5168 may be also applicable for MBI5169.

For MBI5169, the pin 4, LE(ED1), and the pin 13, \overline{OE} (ED2), can be acted as different functions as follows:

Pin	Device Name	MBI5169
	Function Description of Pin 4	LE + Error Detection (ED1)
	Function Description of Pin 13	\overline{OE} + Error Detection (ED2)

MBI5169 8-bit Constant Current LED Sink Driver with Error Detection

Terminal Description

PIN NO.	PIN NAME	FUNCTION
1	GND	Ground terminal for control logic and current sink
2	SDI	Serial-data input to the Shift Register
3	CLK	Clock input terminal for data shift on rising edge
4	LE(ED1)	Data strobe input terminal Serial data is transferred to the respective latch when LE(ED1) is high. The data is latched when LE(ED1) goes low. Also, a control signal input for Error Detection mode (See Timing Diagram)
5-12	$\overline{\text{OUT0}} \sim \overline{\text{OUT7}}$	Constant current output terminals
13	$\overline{\text{OE}} \text{ (ED2)}$	Output enable terminal When (active) low, the output drivers are enabled; when high, all output drivers are turned OFF (blanked). Also, a control signal input for Error Detection mode (See Timing Diagram)
14	SDO	Serial-data output to the following SDI of next driver IC
15	R-EXT	Input terminal used to connect an external resistor for setting up all output current
16	VDD	5V supply voltage terminal

Pin Description

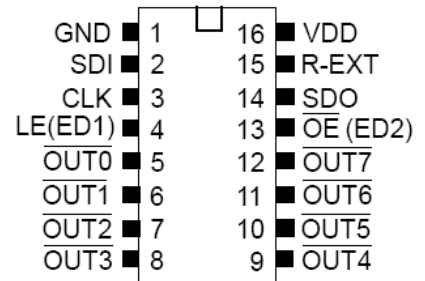

Block Diagram

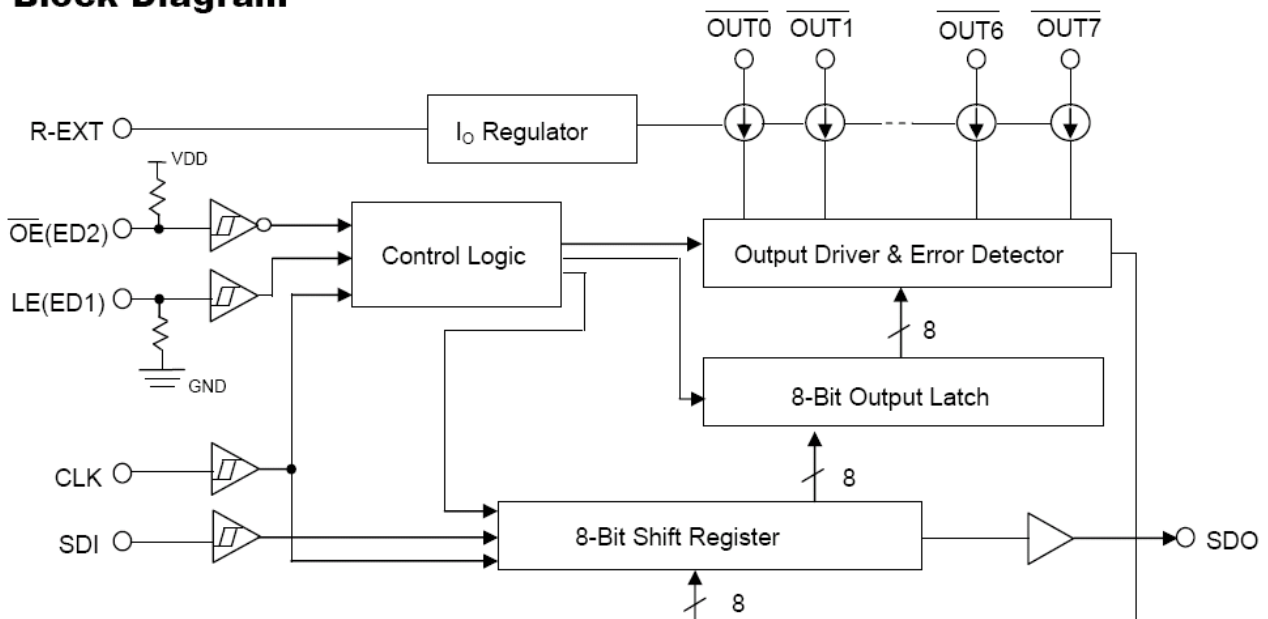

MBI5169 8-bit Constant Current LED Sink Driver with Error Detection

Equivalent Circuits of Inputs and Outputs

\overline{OE} (ED2) terminal

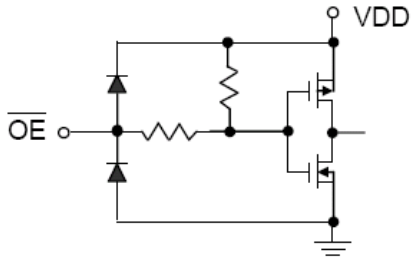

LE(ED1) terminal

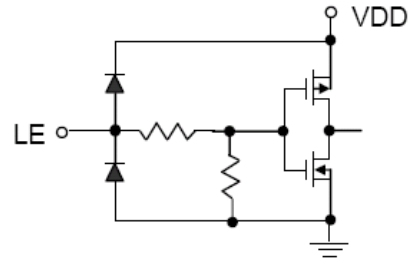

CLK, SDI terminal

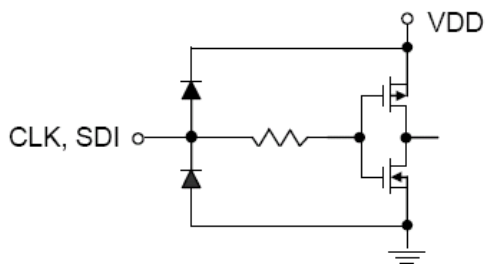

SDO terminal

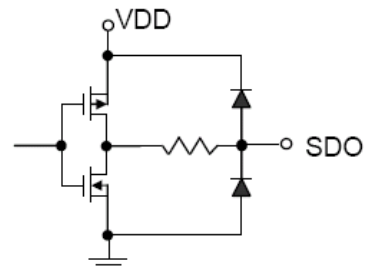

MBI5169 8-bit Constant Current LED Sink Driver with Error Detection

Timing Diagram

Normal Mode

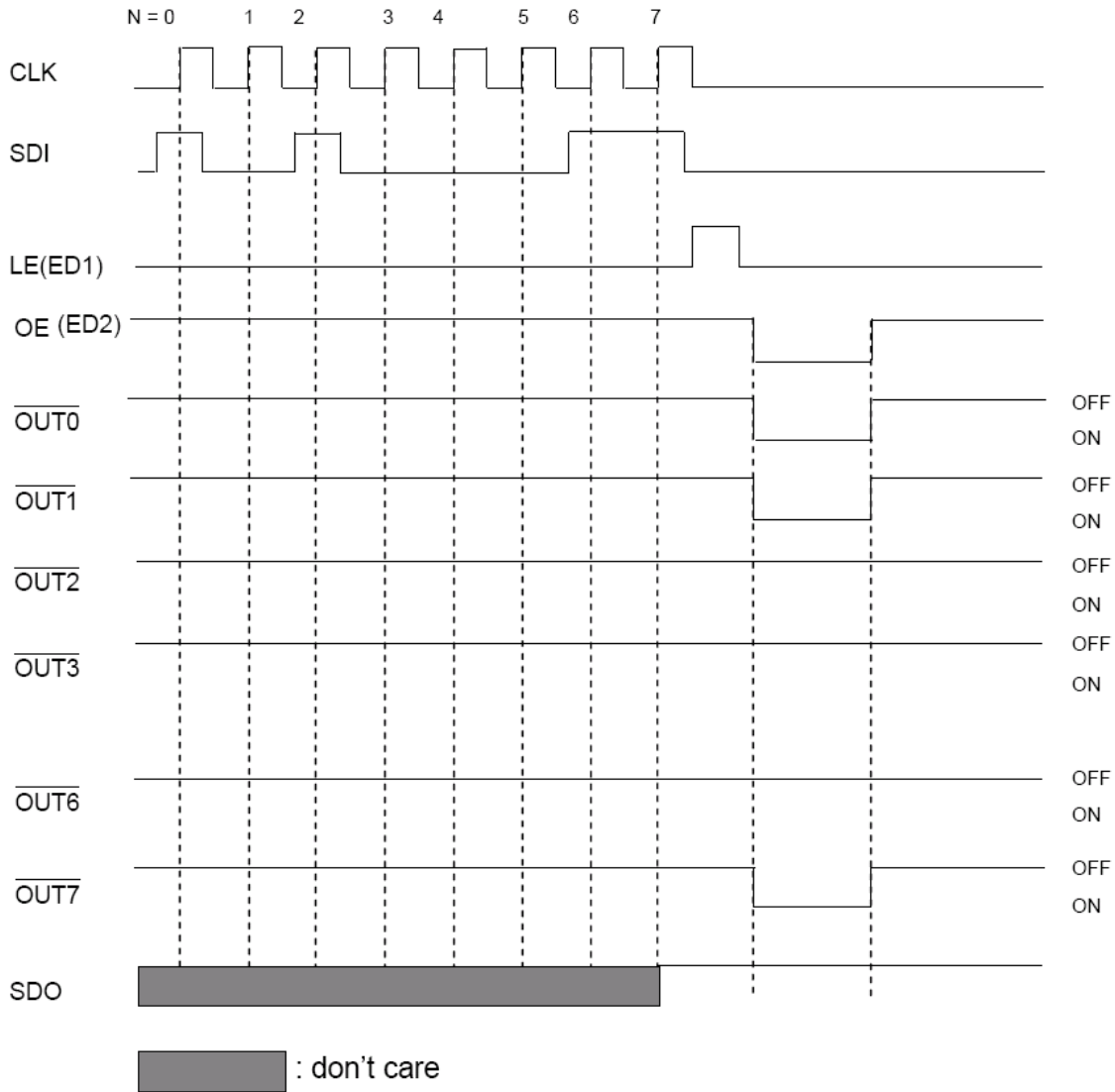

Truth Table (In Normal Mode)

CLK	LE	$\overline{\text{OE}}$	SDI	$\overline{\text{OUT0}} \dots \overline{\text{OUT5}} \dots \overline{\text{OUT7}}$	SDO
\uparrow	H	L	D_n	$\overline{D_n} \dots \overline{D_{n-5}} \dots \overline{D_{n-7}}$	D_{n-7}
\uparrow	L	L	D_{n+1}	No Change	D_{n-6}
\uparrow	H	L	D_{n+2}	$\overline{D_{n+2}} \dots \overline{D_{n-3}} \dots \overline{D_{n-5}}$	D_{n-5}
\downarrow	X	L	D_{n+3}	$\overline{D_{n+2}} \dots \overline{D_{n-3}} \dots \overline{D_{n-5}}$	D_{n-5}
\downarrow	X	H	D_{n+3}	Off	D_{n-5}

MBI5169 8-bit Constant Current LED Sink Driver with Error Detection

Timing Diagram

Normal Mode

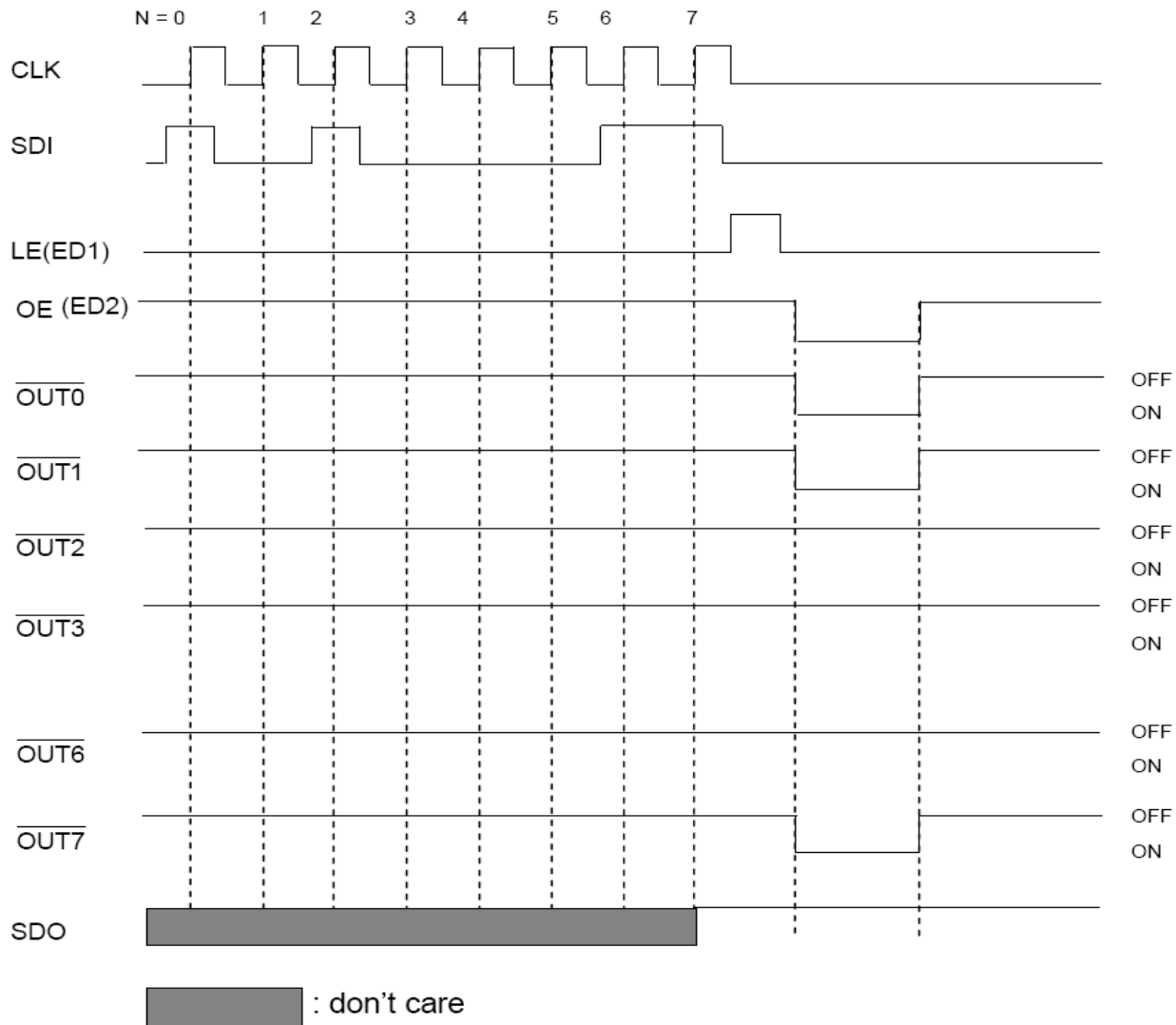

Truth Table (In Normal Mode)

CLK	LE	$\overline{\text{OE}}$	SDI	$\overline{\text{OUT0}} \dots \overline{\text{OUT5}} \dots \overline{\text{OUT7}}$	SDO
\uparrow	H	L	D_n	$\overline{D_n} \dots \overline{D_{n-5}} \dots \overline{D_{n-7}}$	D_{n-7}
\uparrow	L	L	D_{n+1}	No Change	D_{n-6}
\uparrow	H	L	D_{n+2}	$\overline{D_{n+2}} \dots \overline{D_{n-3}} \dots \overline{D_{n-5}}$	D_{n-5}
\downarrow	X	L	D_{n+3}	$\overline{D_{n+2}} \dots \overline{D_{n-3}} \dots \overline{D_{n-5}}$	D_{n-5}
\downarrow	X	H	D_{n+3}	Off	D_{n-5}

MBI5169 8-bit Constant Current LED Sink Driver with Error Detection

Entering Error Detection Mode

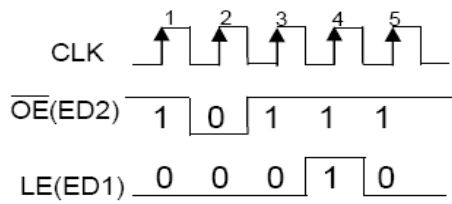

The signal sequence makes MBI5169 enter an Error Detection mode.

Reading Error Status Code

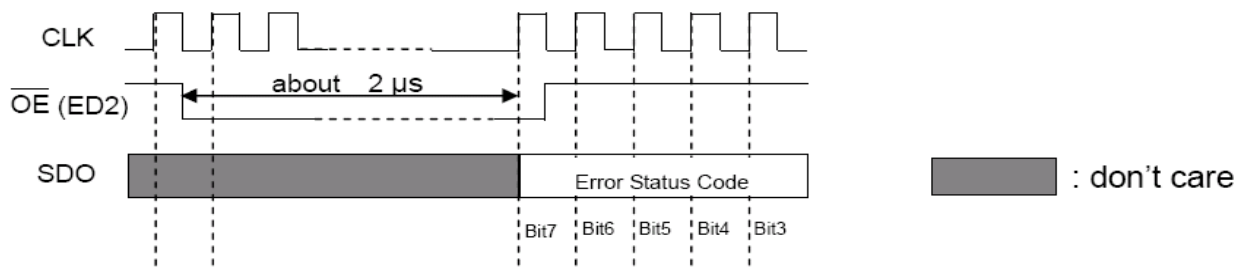

A system controller can read Error Status codes through SDO pin.

Resuming to Normal Mode

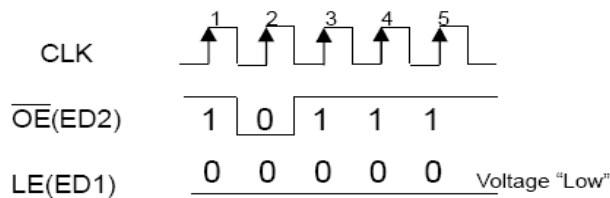

The signal sequence makes MBI5169 resume to the Normal mode.

Note:

If users want to know the whole process, that is how to enter the Error Detection mode, read Error Status codes and resume to the Normal mode, please refer to the contents in **Application Information**.

MBI5169 8-bit Constant Current LED Sink Driver with Error Detection

Maximum Ratings

CHARACTERISTIC		SYMBOL	RATING	UNIT
Supply Voltage		V_{DD}	0~7.0	V
Input Voltage		V_{IN}	-0.4~ $V_{DD} + 0.4$	V
Output Current		I_{OUT}	+120	mA
Output Voltage		V_{DS}	-0.5~+20.0	V
Clock Frequency		F_{CLK}	25	MHz
GND Terminal Current		I_{GND}	960	mA
Power Dissipation (On PCB, $T_a=25^{\circ}C$)	CN – type	P_D	1.64	W
	CD – type		1.06	
	CP – type		0.88	
Thermal Resistance (On PCB, $T_a=25^{\circ}C$)	CN – type	$R_{th(j-a)}$	76	$^{\circ}C/W$
	CD – type		117	
	CP – type		141	
Operating Temperature		T_{opr}	-40~+85	$^{\circ}C$
Storage Temperature		T_{stg}	-55~+150	$^{\circ}C$

MBI5169 8-bit Constant Current LED Sink Driver with Error Detection

Recommended Operating Conditions

Characteristic	Symbol	Condition	Min.	Typ.	Max.	Unit
Supply Voltage	V_{DD}	-	4.5	5.0	5.5	V
Output Voltage	V_{DS}	$\overline{OUT0} \sim \overline{OUT7}$	-	-	17.0	V
Output Current	I_{OUT}	DC Test Circuit	5	-	120	mA
	I_{OH}	SDO	-	-	-1.0	mA
	I_{OL}	SDO	-	-	1.0	mA
Input Voltage	V_{IH}	CLK, \overline{OE} (ED2), LE(ED1) and SDI	$0.8V_{DD}$	-	$V_{DD}+0.3$	V
	V_{IL}	CLK, \overline{OE} (ED2), LE(ED1) and SDI	-0.3	-	$0.3V_{DD}$	V
LE(ED1) Pulse Width	$t_{w(L)}$	Normal Mode $V_{DD}=4.5\sim 5.5V$	40	-	-	ns
CLK Pulse Width	$t_{w(CLK)}$		20	-	-	ns
\overline{OE} (ED2) Pulse Width	$t_{w(OE)}$		400	-	-	ns
Setup Time for SDI	$t_{su(D)}$		5	-	-	ns
Hold Time for SDI	$t_{h(D)}$		10	-	-	ns
Setup Time for LE(ED1)	$t_{su(L)}$		15	-	-	ns
Hold Time for LE(ED1)	$t_{h(L)}$		15	-	-	ns
\overline{OE} (ED2) Pulse Width	$t_{w(ED2)}$	Error Detection Mode $V_{DD}=4.5\sim 5.5V$	2	-	-	μs
CLK Pulse Width	$t_{w(CLK)}$		20	-	-	ns
Setup Time for LE(ED1)	$t_{su(ED1)}$		5	-	-	ns
Hold Time for LE(ED1)	$t_{h(ED1)}$		10	-	-	ns
Setup Time for \overline{OE} (ED2)	$t_{su(ED2)}$		5	-	-	ns
Hold Time for \overline{OE} (ED2)	$t_{h(ED2)}$		10	-	-	ns
Clock Frequency	F_{CLK}	Cascade Operation	-	-	25.0	MHz
Power Dissipation	P_D	$T_a=85^\circ C$	-	-	0.85	W
			-	-	0.55	
			-	-	0.46	

MBI5169 8-bit Constant Current LED Sink Driver with Error Detection

Electrical Characteristics

CHARACTERISTIC		SYMBOL	CONDITION		MIN.	TYP.	MAX.	UNIT
Input Voltage	"H" level	V_{IH}	$T_a = -40\sim 85^\circ\text{C}$		$0.8V_{DD}$	-	V_{DD}	V
	"L" level	V_{IL}	$T_a = -40\sim 85^\circ\text{C}$		GND	-	$0.3V_{DD}$	V
Output Leakage Current		I_{OH}	$V_{OH}=17.0\text{V}$		-	-	0.5	μA
Output Voltage	SDO	V_{OL}	$I_{OL}=+1.0\text{mA}$		-	-	0.4	V
		V_{OH}	$I_{OH}=-1.0\text{mA}$		4.6	-	-	V
Output Current 1		I_{OUT1}	$V_{DS}=0.6\text{V}$	$R_{ext}=744\ \Omega$	-	25.0	-	mA
Current Skew		dI_{OUT1}	$I_{OUT}=25\text{mA}$ $V_{DS}=0.6\text{V}$	$R_{ext}=744\ \Omega$	-	± 1	± 4	%
Output Current 2		I_{OUT2}	$V_{DS}=0.6\text{V}$	$R_{ext}=372\ \Omega$	-	50.0	-	mA
Current Skew		dI_{OUT2}	$I_{OUT}=50\text{mA}$ $V_{DS}=0.6\text{V}$	$R_{ext}=372\ \Omega$	-	± 1	± 4	%
Output Current 3		I_{OUT3}	$V_{DS}=0.8\text{V}$	$R_{ext}=186\ \Omega$	-	100	-	mA
Current Skew		dI_{OUT3}	$I_{OUT}=100\text{mA}$ $V_{DS}=0.8\text{V}$	$R_{ext}=186\ \Omega$	-	± 1	± 6	%
Output Current vs. Output Voltage Regulation		$\%/dV_{DS}$	V_{DS} within 1.0V and 3.0V		-	± 0.1	-	% / V
Output Current vs. Supply Voltage Regulation		$\%/dV_{DD}$	V_{DD} within 4.5V and 5.5V		-	± 1	-	% / V
Pull-up Resistor		$R_{IN(up)}$	\overline{OE} (ED2)		250	500	800	K Ω
Pull-down Resistor		$R_{IN(down)}$	LE(ED1)		250	500	800	K Ω
Open Circuit Error*** Discrimination Voltage		$V_{DS, Th1}$	When all output ports sink 20mA simultaneously		TBD	-	-	V
		$V_{DS, Th2}$	When a single output port sinks 20mA		TBD	-	-	V
		$V_{DS, Th3}$	When all output ports sink 50mA simultaneously		TBD	-	-	V
		$V_{DS, Th4}$	When a single output port sinks 50mA		TBD	-	-	V
Supply Current	"OFF"	$I_{DD(off) 1}$	$R_{ext}=\text{Open}, \overline{OUT0} \sim \overline{OUT7} =\text{Off}$		-	9	-	mA
		$I_{DD(off) 2}$	$R_{ext}=744\ \Omega, \overline{OUT0} \sim \overline{OUT7} =\text{Off}$		-	10	-	
		$I_{DD(off) 3}$	$R_{ext}=372\ \Omega, \overline{OUT0} \sim \overline{OUT7} =\text{Off}$		-	11	-	
	"ON"	$I_{DD(on) 1}$	$R_{ext}=744\ \Omega, \overline{OUT0} \sim \overline{OUT7} =\text{On}$		-	10	-	
		$I_{DD(on) 2}$	$R_{ext}=372\ \Omega, \overline{OUT0} \sim \overline{OUT7} =\text{On}$		-	11	-	

*** To effectively detect the error occurring at the output port, MBI5169 has a built-in current detection circuit. The current detection circuit will detect the effective current $I_{OUT, effective}$, and compare the effective current $I_{OUT, effective}$ to the target current $I_{OUT, target}$, defined by R_{ext} . If $I_{OUT, effective}$ is much less than the target current $I_{OUT, target}$, an error flag will be asserted in the built-in Shift Register. The minimum voltage requirement for such current detection is $V_{DS, Th1}$, $V_{DS, Th2}$, $V_{DS, Th3}$ and $V_{DS, Th4}$.

MBI5169 8-bit Constant Current LED Sink Driver with Error Detection

Test Circuit for Electrical Characteristics

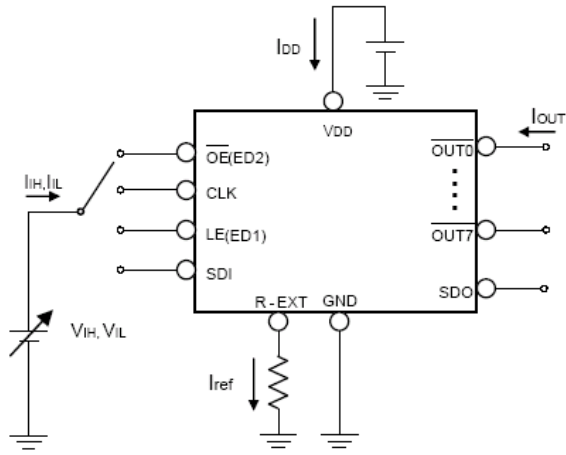

MBI5169 8-bit Constant Current LED Sink Driver with Error Detection

Switching Characteristics

CHARACTERISTIC		SYMBOL	CONDITION	MIN.	TYP.	MAX.	UNIT
Propagation Delay Time ("L" to "H")	CLK - $\overline{\text{OUTn}}$	t_{pLH1}	$V_{DD}=5.0\text{ V}$ $V_{DS}=0.8\text{ V}$ $V_{IH}=V_{DD}$ $V_{IL}=GND$ $R_{ext}=366\ \Omega$ $V_L=4.0\text{ V}$ $R_L=52\ \Omega$ $C_L=10\text{ pF}$	-	50	100	ns
	LE(ED1) - $\overline{\text{OUTn}}$	t_{pLH2}		-	50	100	ns
	$\overline{\text{OE}}$ (ED2) - $\overline{\text{OUTn}}$	t_{pLH3}		-	20	100	ns
	CLK - SDO	t_{pLH}		15	20	-	ns
Propagation Delay Time ("H" to "L")	CLK - $\overline{\text{OUTn}}$	t_{pHL1}		-	100	150	ns
	LE(ED1) - $\overline{\text{OUTn}}$	t_{pHL2}		-	100	150	ns
	$\overline{\text{OE}}$ (ED2) - $\overline{\text{OUTn}}$	t_{pHL3}		-	50	150	ns
	CLK - SDO	t_{pHL}		15	20	-	ns
Pulse Width	CLK	$t_{w(CLK)}$		20	-	-	ns
	LE(ED1)	$t_{w(L)}$		20	-	-	ns
	$\overline{\text{OE}}$ (ED2)	$t_{w(OE)}$		400	-	-	ns
Hold Time for LE(ED1)		$t_{h(L)}$		5	-	-	ns
Setup Time for LE(ED1)		$t_{su(L)}$	5	-	-	ns	
Maximum CLK Rise Time		t_r^{**}	-	-	500	ns	
Maximum CLK Fall Time		t_f^{**}	-	-	500	ns	
Output Rise Time of Iout		t_{or}	-	70	200	ns	
Output Fall Time of Iout		t_{of}	-	40	120	ns	

**If the devices are connected in cascade and t_r or t_f is large, it may be critical to achieve the timing required for data transfer between two cascaded devices.

Test Circuit for Switching Characteristics

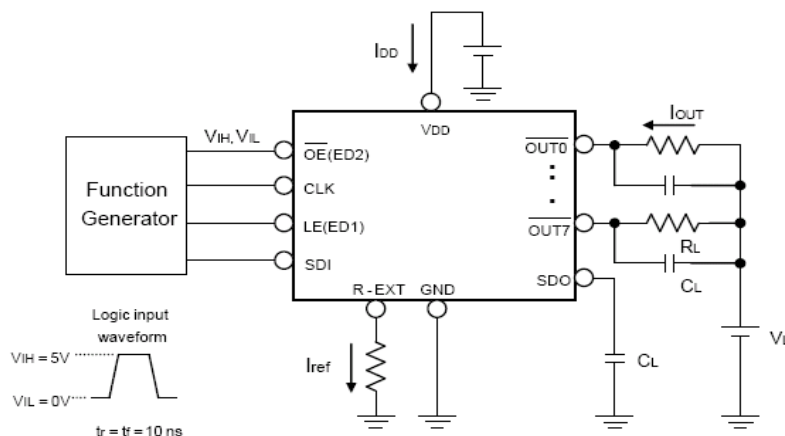

MBI5169 8-bit Constant Current LED Sink Driver with Error Detection

Timing Waveform

Normal Mode

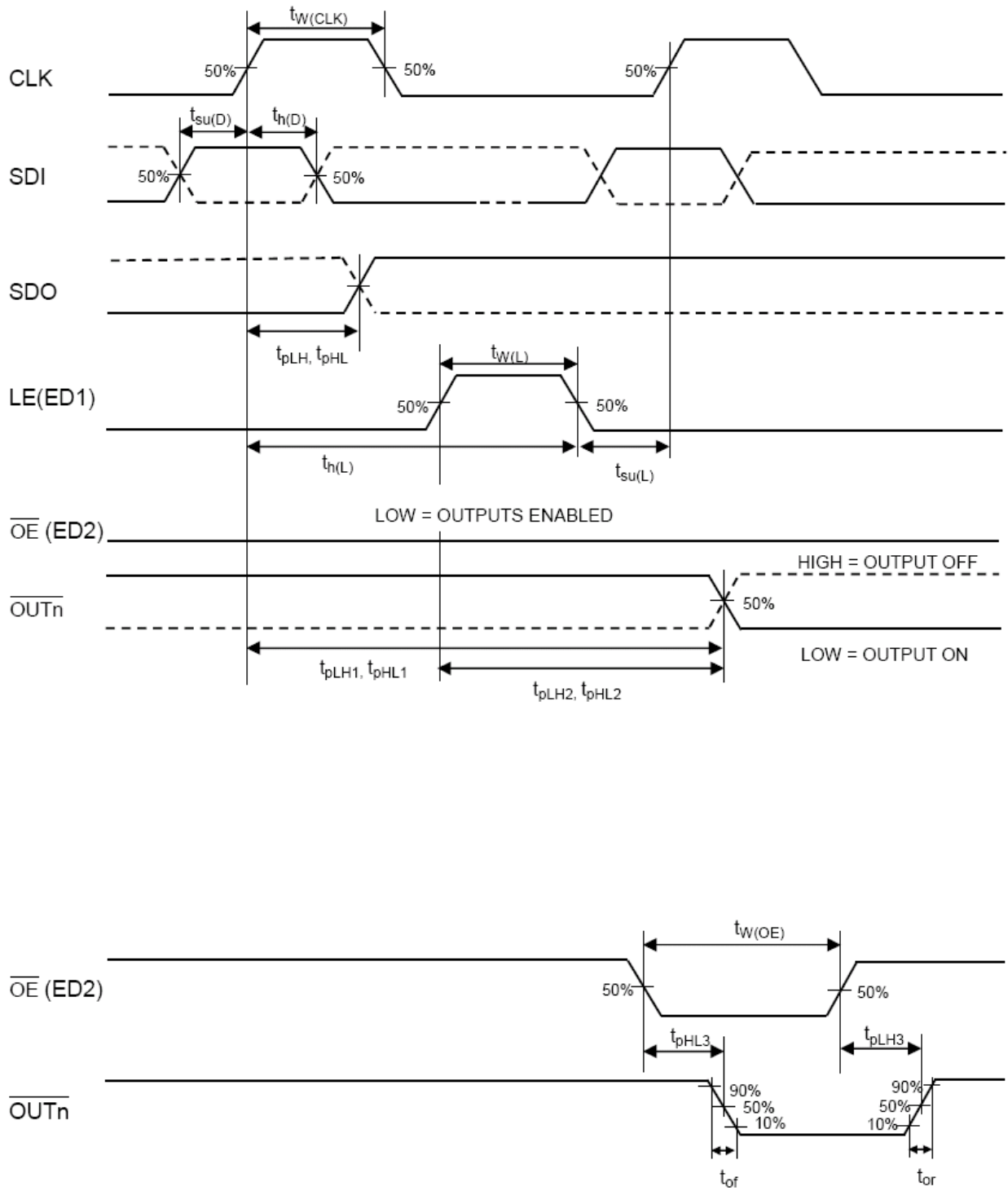

MBI5169 8-bit Constant Current LED Sink Driver with Error Detection

Entering Error Detection Mode

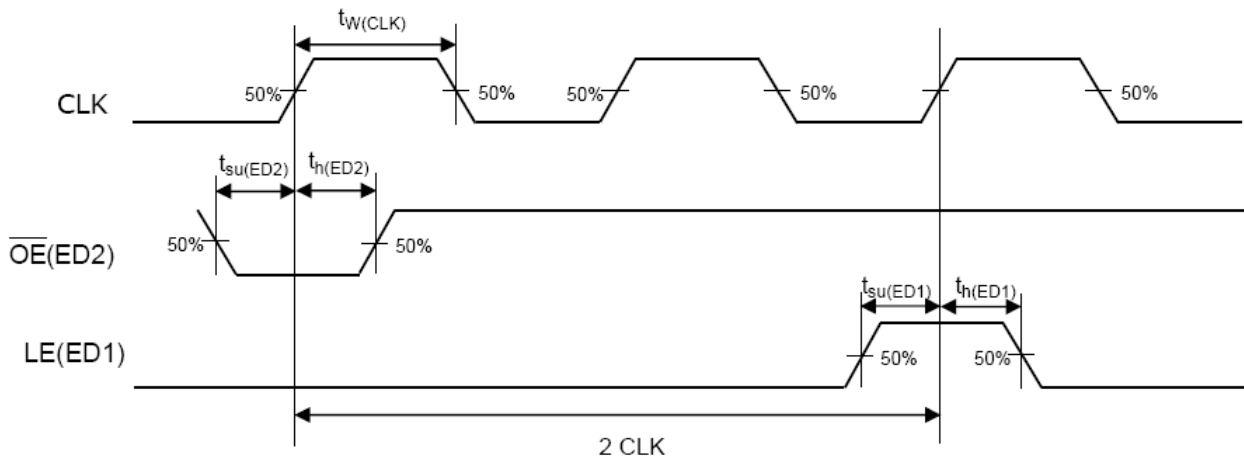

Reading Error Status Code

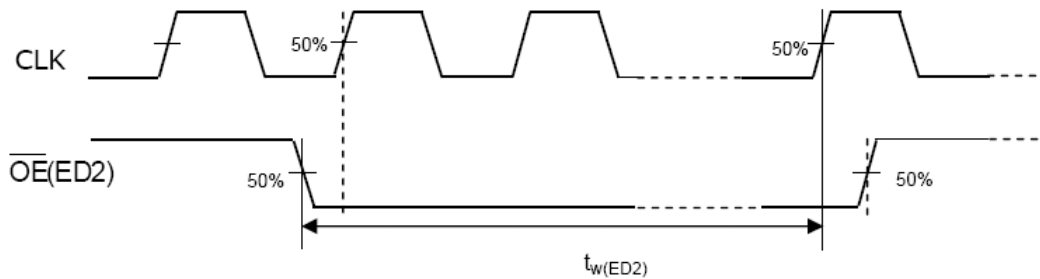

MBI5169 8-bit Constant Current LED Sink Driver with Error Detection

Application Information

Constant Current

To design LED displays, MBI5168 provides nearly no variations in current from channel to channel and from IC to IC. This can be achieved by:

- 1) While $I_{OUT} \leq 60\text{mA}$, the maximum current variation between channels is less than $\pm 4\%$, and that between ICs is less than $\pm 6\%$.
- 2) In addition, the current characteristic of output stage is flat and users can refer to the figure as shown below. The output current can be kept constant regardless of the variations of LED forward voltages (V_f). This performs as a perfection of load regulation.

Adjusting Output Current

The output current of each channel (I_{OUT}) is set by an external resistor, R_{ext} . The relationship between I_{out} and R_{ext} is shown in the following figure.

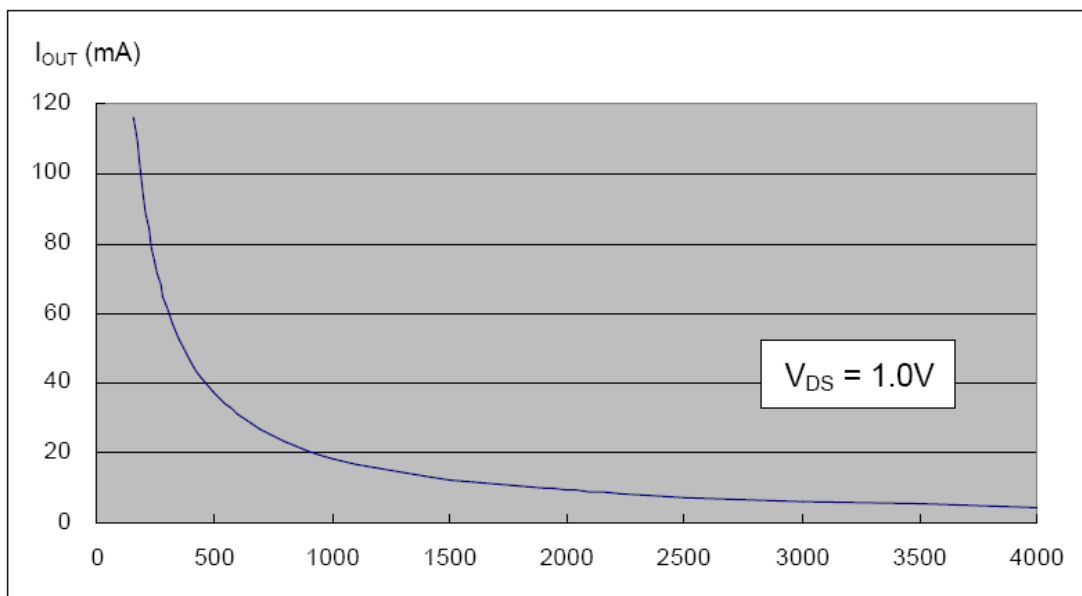

Resistance of the external resistor, R_{ext} , in Ω

Also, the output current in milliamps can be calculated from the equation:

I_{OUT} is $(620 / R_{ext}) \times 30$, approximately,

where R_{ext} , in Ω , is the resistance of the external resistor connected to R-EXT terminal.

The magnitude of current (as a function of R_{ext}) is around 50mA at 372 Ω and 25mA at 744 Ω .

MBI5169 8-bit Constant Current LED Sink Driver with Error Detection

Resuming to Normal Mode

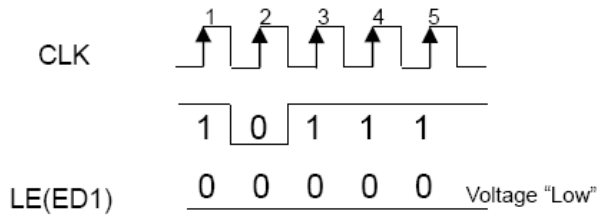

Each time the system controller sends the sequence patterns shown above, MBI5169 can resume to the Normal mode. During this phase, the system controller can still send data through SDI pin.

The state of \overline{OE} (ED2) and LE(ED1) is sampled by the rising edge of each CLK. We use "0" and "1" to represent the state of "Voltage Low" and "Voltage High" respectively. The states of the successive five \overline{OE} (ED2) and LE(ED1) are (1, 0), (0, 0), (1, 0), (1, 0) and (1, 0).

MBI5169

8-bit Constant Current LED Sink Driver with Error Detection

Timing Chart for Error Detection Mode (An Example)

N x MBI5169 are connected in cascade, ie, SDO, k -> SDI, k+1.
 And, all MBI5169 ICs are connected to the same CLK, LE(ED1) and OE(ED2) signals.

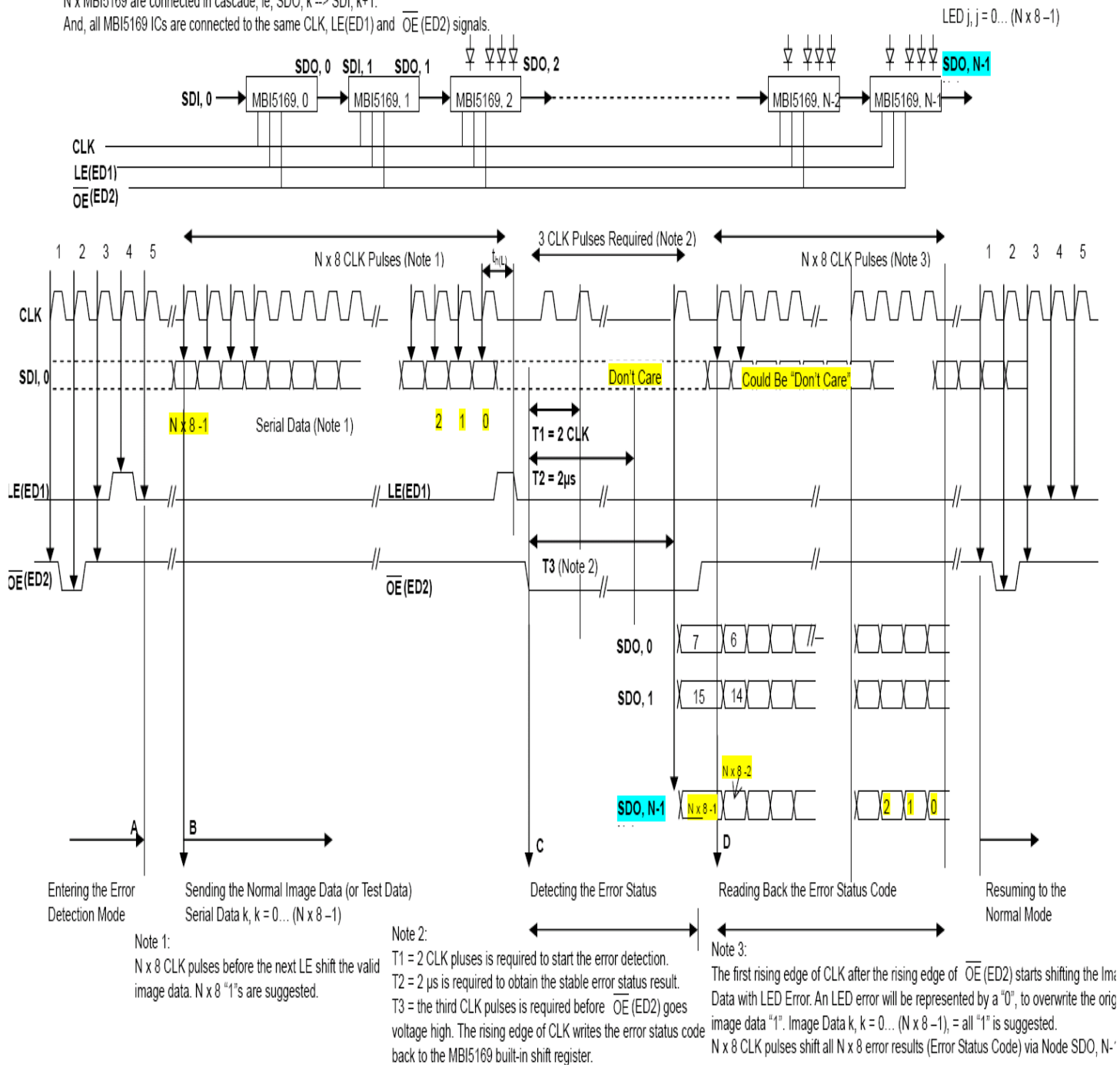

MBI5169 8-bit Constant Current LED Sink Driver with Error Detection

Package Power Dissipation (P_D)

The maximum allowable package power dissipation is determined as $P_{D(max)} = (T_j - T_a) / R_{th(j-a)}$. When 8 output channels are turned on simultaneously, the actual package power dissipation is $P_{D(act)} = (I_{DD} \times V_{DD}) + (I_{OUT} \times Duty \times V_{DS} \times 8)$. Therefore, to keep $P_{D(act)} \leq P_{D(max)}$, the allowable maximum output current as a function of duty cycle is:

$$I_{OUT} = \{ [(T_j - T_a) / R_{th(j-a)}] - (I_{DD} \times V_{DD}) \} / V_{DS} / Duty / 8,$$

where $T_j = 150^\circ\text{C}$.

Load Supply Voltage (V_{LED})

MBI5168 are designed to operate with V_{DS} ranging from 0.4V to 1.0V considering the package power dissipating limits. V_{DS} may be higher enough to make $P_{D(act)} > P_{D(max)}$ when $V_{LED} = 5V$ and $V_{DS} = V_{LED} - V_f$. In this case, it is recommended to use the lowest possible supply voltage or to set an external voltage reducer, V_{DROP} .

A voltage reducer lets $V_{DS} = (V_{LED} - V_f) - V_{DROP}$.

Resistors or Zener diode can be used in the applications as shown in the following figures.

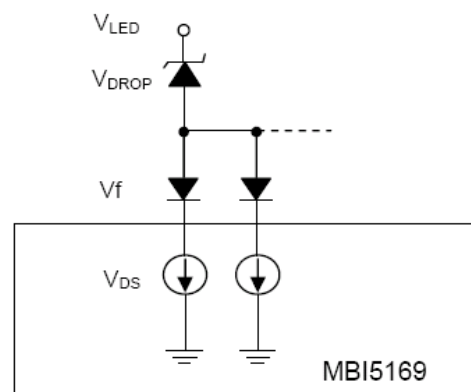
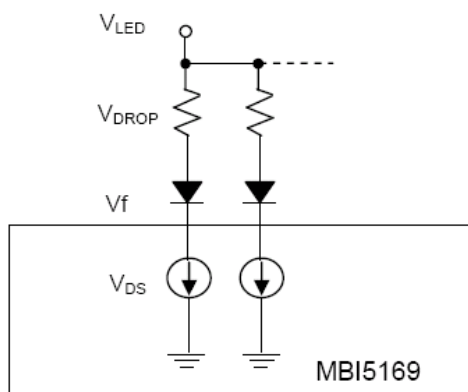

MBI5169 8-bit Constant Current LED Sink Driver with Error Detection

Outline Drawings

MBI5169CN

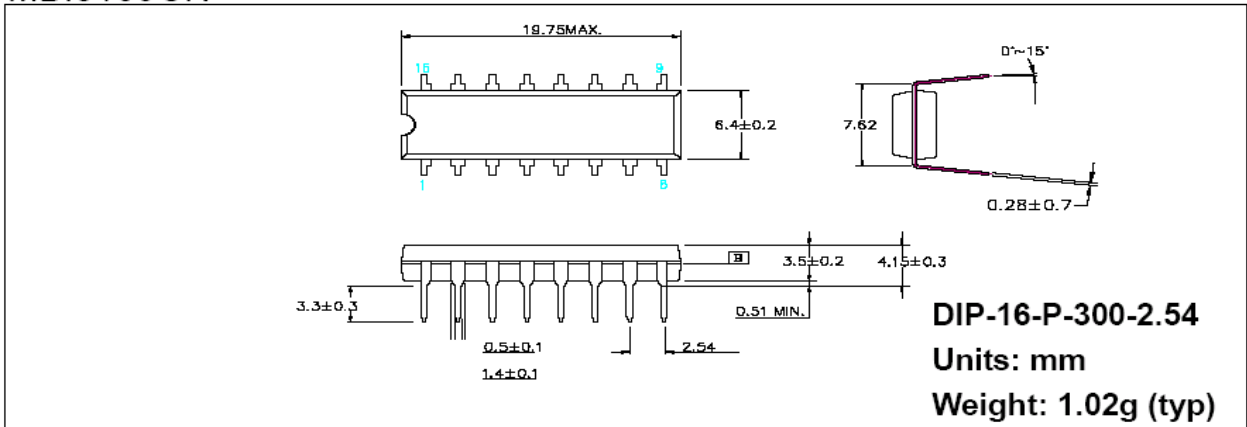

MBI5169CD

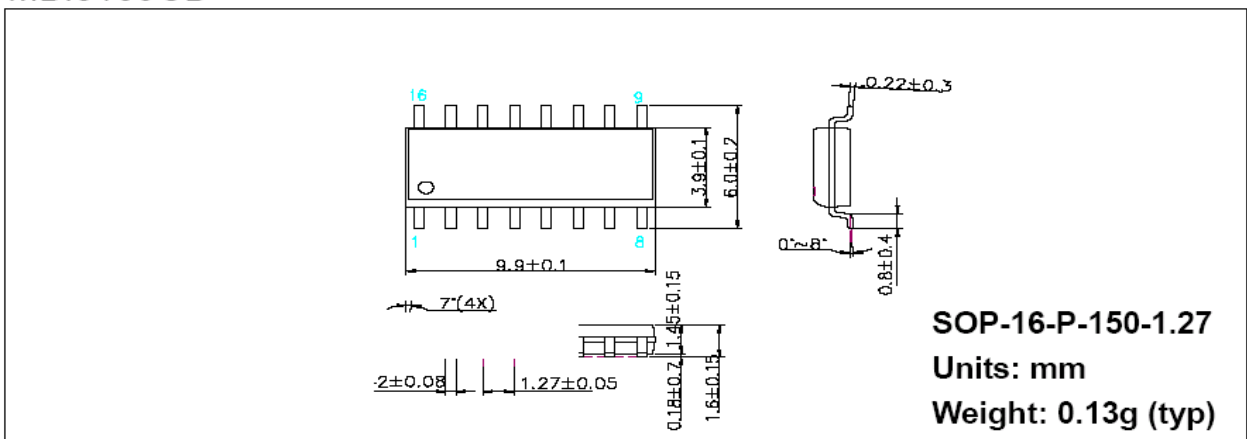

MBI5169CP

